

Wing Nuts

Stainless Steel AISI 316, Hygienic Design

SPECIFICATION

Stainless steel precision casting

- AISI 316
- Matte finish (Ra < 0.8 μm) **MT**
- Polished finish (Ra < 0.8 μm) **PL**

Sealing ring

- H-NBR **H**
Temperature resistant -25 °C to +150 °C
- EPDM **E**
Temperature resistant -40 °C to +120 °C
- Blue
- Hardness 85 ±5 Shore A
- FDA compliant

INFORMATION

Wing nuts GN 8341 are intended for use in hygienic areas. The sealed mounting surface enables mounting without dead spaces; the impervious geometry in combination with the high quality finish prevents the accumulation of dirt and facilitates cleaning. Wing nuts clamp and fasten parts easily without tools. The ergonomic shape allows for high tightening forces. The wing nuts can also be used in particularly aggressive environments thanks to the material used.

ACCESSORY

- Sealing Rings GN 7600 (see page)

TECHNICAL INFORMATION

- Plastic Characteristics (see page A2)
- Stainless Steel Characteristics (see page A26)

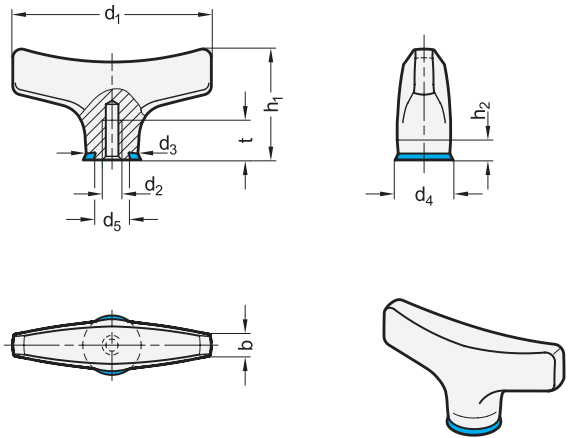

* Complete with surface index of the Wing Nuts (MT or PL)

- | | |
|--------------|-----------------|
| MT | PL |
| Matte finish | Polished finish |

GN 8341-H

STAINLESS STEEL

Description	d1	d2	b	d3	d4	d5	h1	h2 ≈	t min.	Δ
GN 8341-40-M4-*-H	40	M 4	4	11	11.8	7	22	4	8	29
GN 8341-50-M5-*-H	50	M 5	5	13	13.8	9	28	5	10	54
GN 8341-63-M6-*-H	63	M 6	7	16	16.8	12	35	6	12	100

GN 8341-E

STAINLESS STEEL

Description	d1	d2	b	d3	d4	d5	h1	h2 ≈	t min.	Δ
GN 8341-40-M4-*-E	40	M 4	4	11	11.8	7	22	4	8	29
GN 8341-50-M5-*-E	50	M 5	5	13	13.8	9	28	5	10	54
GN 8341-63-M6-*-E	63	M 6	7	16	16.8	12	35	6	12	100

Weight type MT